

Combustion, Fuels and Emissions for Industrial Gas Turbines

Michael Welch

Industry Marketing Manager
Siemens Industrial Turbomachinery Ltd
LN5 7FD, Lincoln, England

Brian M Igoe

Expert Proposal Manager
Siemens Industrial Turbomachinery Ltd
LN5 7FD, Lincoln, England



Mike Welch is Industry Marketing Manager – Oil & Gas for Siemens Industrial Turbomachinery Ltd. Based in Lincoln, UK, Mike is responsible for promoting Siemens' ranges of Gas Turbines in Oil & Gas applications around the World.

Mike has an Honours Degree in Electrical and Electronic Engineering from Loughborough University of Technology and has worked in both Sales and Engineering roles with Rotating Machinery for 25 years. Mike is a Member of the Institute of Engineering and Technology (IET).



Brian Igoe has been working in rotating equipment for more than 30 years. As an Expert Proposal Manager for the FEED team of Siemens Industrial Turbomachinery Ltd, Lincoln, England, he is responsible for supporting gas turbine applications including performance, fuels and emissions at the early stages of projects. Brian also

provides a range of training internally within Siemens as well as to external groups. Brian was awarded an Honours Degree in Mechanical Engineering from the University of Surrey and a Masters degree from the University of Cranfield. He was elected a Fellow of the Institution of Mechanical Engineers in 2011

ABSTRACT

It is important that gas turbines used in Oil & Gas applications can burn a wide variety of fuels with the minimum impact on the environment or economics.

Many types of gaseous and liquid fuels that can be used in Gas Turbines are discussed, as will be the two basic types of combustion system employed – 'conventional' and 'Dry Low Emissions' – along with the flexibility of these systems to accept different types of fuel. Some of the common contaminants found in fuels are discussed along with the impact these have on the operability and maintenance of industrial and aero-derivative gas turbines.

Topics include:

- Types of gas turbines
- Types of exhaust emissions regulated
- Conventional combustion systems
- Dry Low (Pre-mixed) emissions combustion systems
- Fuel quality requirements
- 'Pipeline' quality Natural Gas fuels
- Premium liquid fuels (diesel, kerosene)
- Wellhead Gases as a Gas Turbine Fuel
- Liquefied Natural Gas (LNG)
- Biogas fuels - Refinery and process off gases
- Syngas
- Natural Gas Liquids and LPG fuels
- Crude Oil
- Operational impact of contaminants
- Water in fuel
- Storing fuels correctly

INTRODUCTION

Gas Turbine Fuels and Emissions

Understanding the need to ensure fuel quality is maintained at a high standard is a key to delivering good operation in a modern gas turbine over long periods of time. However, it is not just fuel that is critical, it is also ensuring all fluids entering the GT are equally kept at a high standard, thus minimizing or eliminating all sources of contaminants.

Delivery of fuel and air to the combustor is one thing, but to ensure the condition of both is optimum is critical to achieving clean and stable combustion. Modern gas turbines operate at high temperatures, and use component designs and materials at the forefront of technology, but these are more susceptible to damage if contaminated fuel and air enter the GT through poor operating procedures. This seminar will consider the need to ensure good quality fluids enter the GT, and why it is necessary, for example, to provide air and fuel free of contaminants to ensure the best availability and reliability of the product.

Combustion technology has moved forwards in achieving low emissions without resorting to wet abatement methods. Both conventional and low emissions technologies are covered and reviewed along with basic operating parameters associated with the fuels in question.

The fuel range used in GT applications is very wide with the

choice based typically on availability and cost. In some cases fuels may have little or no treatment or processing in order to be used as low cost fuels, in others they may have “added value” which results in the high quality pipeline natural gas that provides the fuel of choice for gas turbine OEMs and operators alike. Gas Turbines can, and do, operate on a wide range of fuels, some of which are shown in Table 1 below, but the impact that such fuels may have on turbine life has to be recognised.

turbine types. There are, however, different types of GT available in the market place. The bulk of the content of this paper is based on the experiences for ‘light industrial gas turbines’ but the other main type of construction requires mention. Aero-derivative gas turbines are based on the adaptation of aero engines for ‘land based’ applications.

The method of delivering fuel to both light industrial as well as aero-derivative units is similar, although for the latter the combustion hardware and fuel injection systems are more ‘light weight’ due to the aero heritage and roots. These also tend to operate at significantly higher pressure ratio so require higher fuel supply pressures.

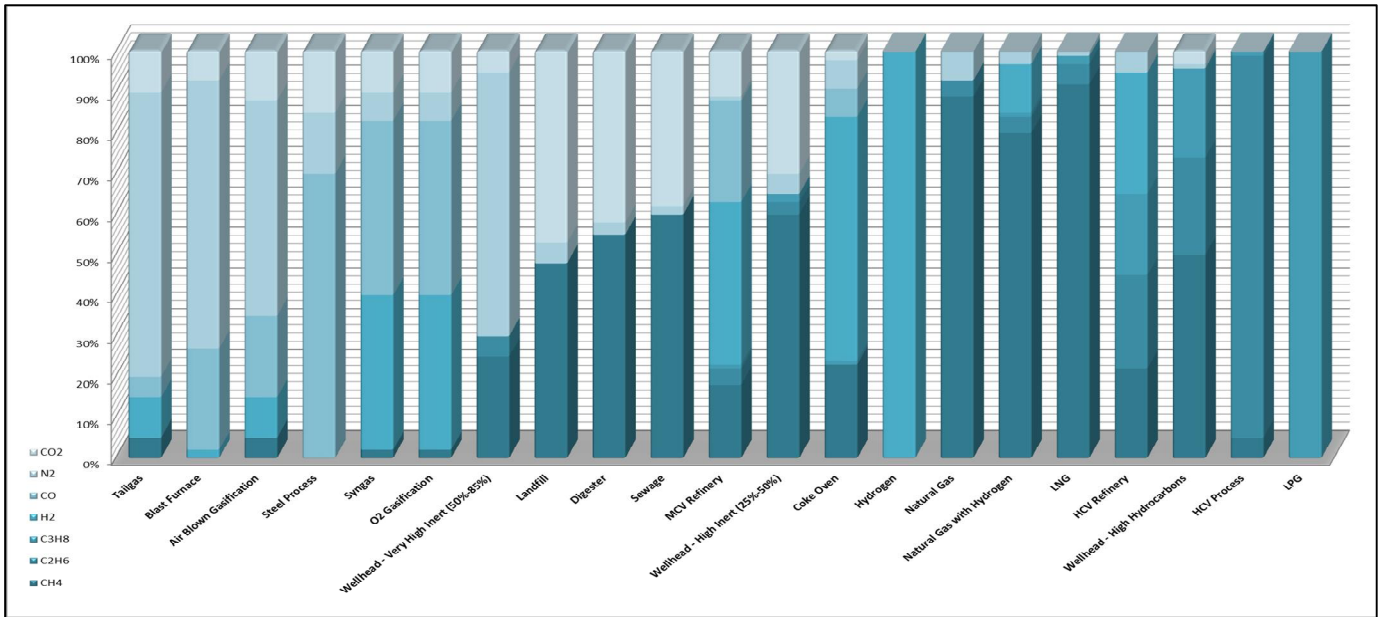

Table 1: Range of gaseous fuels

It is not a simple case of saying these fuels are acceptable or not, but understanding the details of these fuels, such as the composition [hydrocarbon species in the case of a gaseous fuel, inert species, contaminants, water vapour, ...]. Detailed analysis of the fuels is necessary to determine key parameters of the fluid, such as delivery, storage and conditioning as well as key features of the fuel itself, including Lower Heating Value (LHV), Wobbe Index, dew point and density. Understanding all of these provides the OEM and user with indicators that the fuel entering the GT is suitable and can result in good operation across a wide range of loads and ambient conditions. It is also important to determine and understand the products of combustion and impact on the environment. Exhaust emissions are highly regulated in many parts of the world and even those areas that up until recently had no requirements have started to introduce standards or guidelines which need to be noted during the application assessment stage.



Figure 1: Industrial Gas turbine with DLE combustor

This paper mainly concentrates on fuels, combustion and emissions to atmosphere from gas turbines with no mention of



Figure 2: Aero-derivative - LM2500 gas turbine with DLE combustor (courtesy GE Energy)

Types of combustion emissions regulated; Legislation, OEM and Customer Requirements

Over the last 25 years, increasing pressure has been placed on the gas turbine OEM's to develop less polluting products. The US Clean Air Act set new standards for emissions compliance, with the European Union (EU) and other countries soon following suit with more demanding legislative requirements. Consequently low emissions became the norm and not the exception. There are a wide variety of pollutants to consider, but in particular Oxides of Nitrogen (NO_x), Carbon Monoxide (CO) and unburnt hydrocarbons (UHC). {1}

In addition, the major gas turbine OEM's, along with a large number of Oil & Gas companies, have their own policies with regard to environmental stewardship, and offer or specify low emission equipment even in locations where no formal legislation exists, or is set at a higher level.

The result of all of these drivers is to make the Dry Low Emissions or Dry Low NO_x (DLE/DLN) combustion system the primary combustion system of choice. Some GT OEMs offer DLE/DLN as the only combustion system on newer gas turbine models.

Available Combustion Systems

Two types of combustion system are widely used in gas turbines: one based on the 'conventional' diffusion flame; the second uses lean pre-mix technology targeting low exhaust emissions signature. These are offered in both annular and can-annular arrangements.

Conventional Combustion

Conventional combustion (Figure 3), also referred to as diffusion flame combustion, operates at high primary zone temperatures, circa 2500K, resulting in high thermal NO_x formation. Lowering the flame temperature, and hence NO_x production, can be achieved by injection of diluents such as water or steam into the primary zone, which quench the flame, and reduce the production of NO_x. This has been successfully employed for many years across product ranges by many of the gas turbine manufacturers. Generally such combustion systems have been more tolerant to different fuel types. Different OEMs use differing methods for water or steam injection, but all recognize the impact on reliability and life cycle costs.

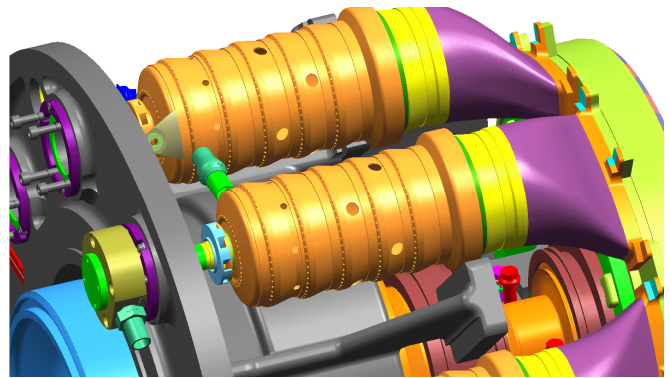

Figure 3: Conventional or Diffusion flame combustion hardware

Figure 4 shows a comparison of injecting water or steam into the primary zone with the newer DLE/DLN solution. {2} Other factors to note with wet injection are the need for a large quantity of de-mineralized water and the impact on the service regime, with more frequent planned interventions a consequence of this option. The ratio of water, or steam, to fuel used (WFR or SFR) results in lower NO_x, but can impact CO emissions in a detrimental manner. Where a service retrofit of existing gas turbines was made to include DLE combustion, the environmental benefit was significant, offering almost a 5 times reduction in NO_x emissions compared to previous abatement system employed (Figure 5).

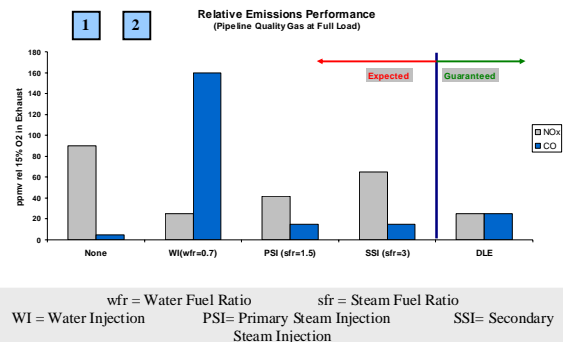

Figure 4: Effects of wet injection on diffusion flame combustor, compared to DLE

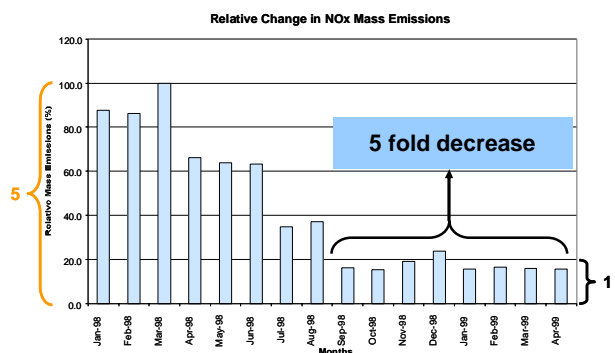

Figure 5: Effect of conversion of multi-engine site from conventional to DLE combustion configuration

Introduction to Dry Low Emissions combustion systems

Lowering primary zone temperatures without resorting to wet diluents is now achieved using lean pre-mix combustion. Dry Low Emissions (DLE) or Dry Low NO_x (DLN) combustion systems address the production of NO_x at source with a design that does not rely on injected diluents, hence the term “dry”. 4 promising technologies were identified.

- 1: Lean-premixed pre-vaporised combustion
- 2: Staged Combustion
- 3: Catalytic Combustion
- 4: Rich-burn lean quench combustion.

Of these, the lean premixed system is the one that has been developed by a number of gas turbine OEMs as the combustion system of choice with many millions of operating hours now recorded. All these methods reduce the production of NO_x by reduction of the reaction temperature. Lower NO_x formation has been achieved by combusting the fuel in an excess of air, hence “lean” pre-mix combustion. NO_x production increases exponentially with temperature, so therefore it is critical to ensure air and fuel is well mixed. During the early design and development work, there was much attention devoted to achieving a homogeneous mixture, and burning this mixture without detrimental impact on combustion and turbine hardware.

A lean pre-mix combustor design comprises 4 main features:

- Fuel / air injection device
- Stability device
- Pre-mixing zone
- Flame stabilization zone

These features are covered and discussed in more detail later.

Meeting emissions requirements is only one aspect of combustion design. It has also to meet operational criteria, including: component life; flexible fuel operation; reliable starting; reliable switching between fuels; reliable transient response; and all without excessive cost.

Methods of reducing NO_x Emissions

There are three main ways for NO_x formation

- thermal NO_x
- prompt NO_x
- fuel bound NO_x (FBN)

Thermal NO_x is by far the most dominant source of NO_x and is produced by the reaction between Nitrogen and Oxygen in the air as described by Zeldovich, {3}. This reaction takes place above 1700K and the rate increases exponentially as temperature increases (figure 6). FBN can only be influenced by removal of nitrogen bearing compounds in the fuel.

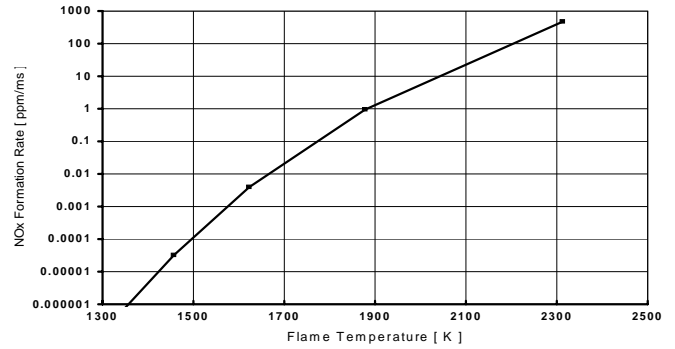

Figure 6: NO_x formation rate, from Zeldovich

DLE design

Figures 7 and 8 show lean pre-mix DLE combustion system designs released into production in the early 1990s and from 2000 respectively{4, 5}.

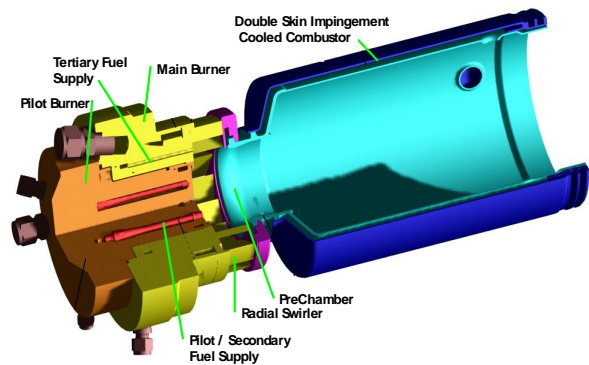

Figure 7: DLE combustion system design circa 1995

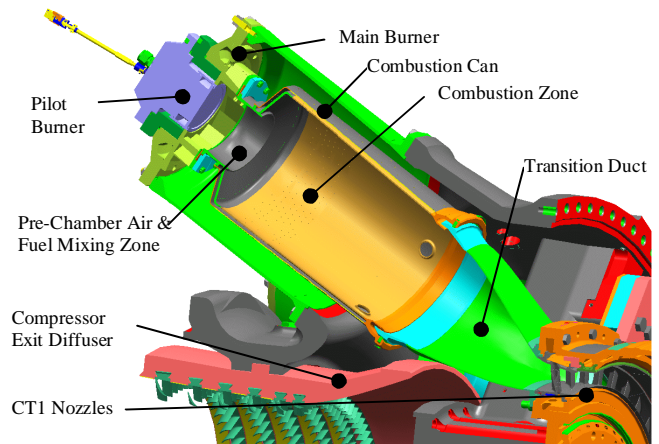

Figure 8: DLE combustion system design 2000

These examples are can-annular solutions. Some manufacturers, including those applied to aero-derivative GTs, apply lean premix within an annular combustion configuration – in this configuration a single combustion chamber is mounted around the outside of the compressor exit section of the gas turbine, with multiple burners mounted through engine casings into holes in the combustor, as shown in Figure 9 (industrial gas turbine), and Figure 10 (aero-derivative gas turbine).

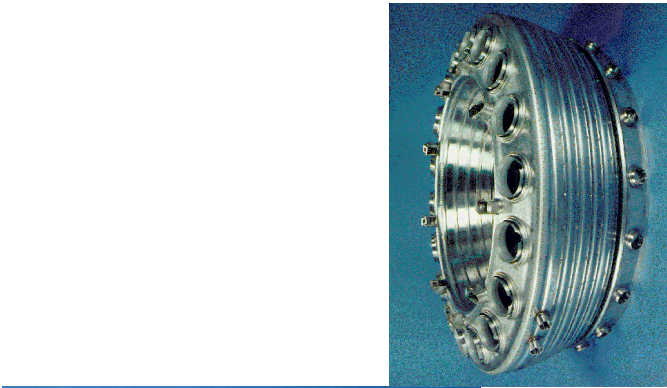

Figure 9: Annular Combustor with 3rd generation DLE burner

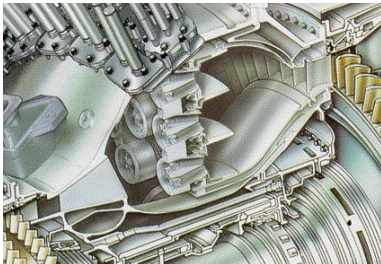

Figure 10: Aero-derivative Annular DLE combustion (courtesy GE Energy)

Diffusion flame comparisons with DLE combustion systems

In order to produce low NO_x and low CO the homogeneous flame temperature within the combustor must be controlled between strict limits. Conventional diffusion flame combustors (Figure 11) have very high temperature primary zones due to high turbulence regions promoting mixing and result in temperatures in excess of 2500K. These high temperature regions lead to high NO_x production rates, resulting in diffusion flame combustors producing NO_x emissions typically greater than 300 Vppmd at 15% O₂. In order to reduce NO_x levels either the temperature within the combustor has to be lowered or the NO_x must be removed after the turbine. Improvements in mixing the fuel and air to achieve a homogeneous mixture whilst at the same time ‘leaning out’ the mixture within the DLE combustor, achieves the desired effect of a more uniform and lower peak combustor temperature, thus resulting in low thermal NO_x production (figure 12).

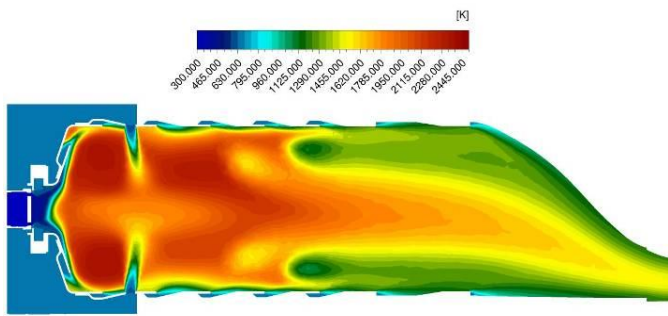

Figure 11: CFD calculation of temperature distribution within a diffusion flame combustor

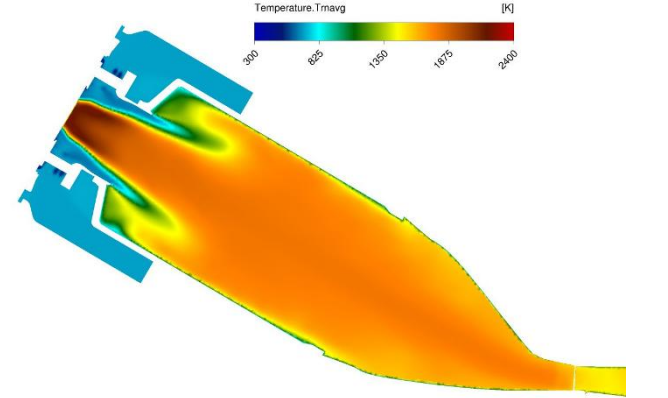

Figure 12: Computation of temperature (in Kelvin) distribution in a DLE lean premixed combustor

Dry Low Emissions Combustion

The design approach for DLE combustion by one OEM is shown in Figure 13 and highlights the use of scaled combustion geometry across the product portfolio and shows the application of can-annular combustion hardware.



Figure 13: Scaled hardware design across the product portfolio

A common design approach was adopted where scaling and adjustments for air flow have been applied depending on the rating and combustor numbers used in the GT model.

The combustor has three main sections (figures 7 & 8):

- i) Fuel injection device - the pilot burner - houses the pilot fuel galleries and injectors for both gaseous and liquid fuel
- ii) Main fuel injection device - the main burner - houses the main air swirler and main gas and liquid fuel systems
- iii) The combustor - the flame mixing and stability device – which includes a narrow inlet feature, called the pre-chamber; is of double skin construction with impingement cooling, this air exhausting into the combustor through dilution holes downstream of the main reaction zone.

A transition duct, located downstream of the combustor, conditions the flow from the circular combustor exit to a sector of the turbine entry annulus.

Figure 14 shows a schematic of the combustion concept. The main combustion air enters through a single radial swirler at the head of the combustor. Flow turns through 90 degrees into the pre-chamber followed by a sudden expansion into the combustion chamber. The swirl number is sufficiently high to induce a vortex breakdown reverse flow zone along the axis. This is termed the internal reverse flow zone. In this design concept the reverse flow zone remains attached to the back surface of the combustor thereby establishing a firm aerodynamic base for flame stabilization. In the wake of the sudden expansion, an external reverse flow zone occurs with flame stabilization in the shear layers around the internal and external reverse flow zones, {6}.

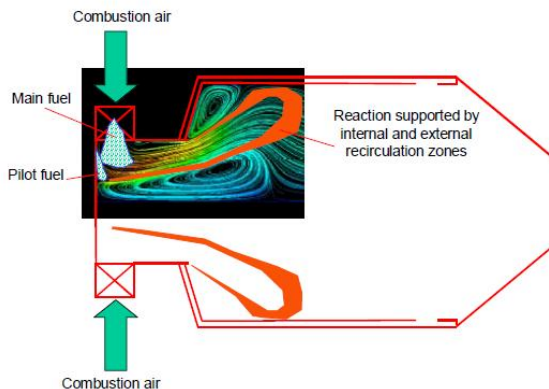

Figure 14: Schematic of the Dry Low Emission combustor concept

Gaseous and liquid fuels are introduced, in two stages:

- Main, which results in a high degree of 'premixedness' and hence low NO_x emissions
- Pilot, which is reduced as the load demand increases and is used to ensure flame stability

The pilot is arranged such that as the pilot fuel split increases, the fuel is biased towards the axis of the combustor.

Describing each element of the DLE system in more detail and referring to Figures 7 and 8 shown earlier:

Pilot burner

The pilot burner provides fuel for ignition and transient operation, with a small percentage used at full load for stability purposes. This allows for rapid response during load rejection conditions, for example a power generation application where a circuit breaker trips and the turbine load changes from exporting electrical power to the grid to simply providing sufficient power to meet customer local demand.

An ignition source is mounted in each pilot burner, along with a thermocouple to monitor the temperature of the face of the burner. For dual fuel units, a separate liquid fuel lance, located and accessed through the rear of the burner, provides fuel for ignition and transient operation.

Main burner

Fuel flow increases as speed and then load is increased. This device provides the pre-mixing via the radial swirler and numerous gas injection ports. The swirlers are fixed design with no moving parts. Control of fuel by fuel valves in the gas fuel module external to the combustor is necessary to achieve both load and ambient temperature control.

Liquid core

Located next to the main swirler/burner is the liquid core when a dual fuel arrangement is required. For a gas fuel only configuration, this core insert is replaced with a blank ring. Liquid is injected through one of six injector nozzles equally spaced around the insert, and lying inboard of the gas injection point in alternate swirler vanes. The good pre-mixing of the fuel with the high velocity air results in good liquid fuel emissions characteristics.

Combustion liner

The main swirler/burner is mounted at the head of the combustor. This comprises a double skin liner, the outer skin controlling the cooling air feeding the annulus between inner and outer liner. The head of the combustor locates the pre-chamber and is where the fuel is mixed prior to ignition

Transition duct

This duct controls and directs the hot combustion gases towards the first stage nozzle and typically includes effusion cooling.

Materials:

All components of the combustion hardware are manufactured from conventional materials typically used in this part of the gas turbine. Burners are routinely made from stainless steel, with the application of a thermal barrier coating in key areas. Combustion chambers are manufactured from Nimonic steels with thermal barrier coatings applied to the inner liner surface.

The description provided above refers typically to arrangements where control of the fuel is maintained across the full operating regime of speed, load and ambient conditions. For other types of configuration, including the annular combustion designs installed in aero-derivative type GT designs should be considered at this point. Due to the light weight construction, multiple small burners tend to be used, with fuel supply based on staging principles. Typically such GT start in diffusion flame (non-premixed) mode with fuel applied to different fuel

nozzles at different load conditions. This is often done to maintain control on fuel air ratio and control narrow flame temperature window. As with industrial type DLE/DLN combustor design, it is essential to balance achieving low NO_x signature without operating in regions resulting in excessive CO emissions and lean blow-out.

Fuel Control and Combustion “tuning”

Accurate fuel control is essential for correct gas turbine operation. The gas turbine package comes equipped with a gas fuel module, complete with all necessary instrumentation, safety valves and the main fuel control valve or valves. On a diffusion flame burner, fuel control is relatively simple: fuel is fed to a single ring manifold which is then connected to all the individual burners, and gas fuel flow into manifold controlled by a single gas fuel control valve.

However, lean pre-mix systems are often more complicated, with pilot burners, multiple main burners and the potential need to vary the fuel flow through each individual burner depending on the gas turbine load. The complexity of the fuel control system varies greatly from manufacturer to manufacturer depending on the DLE combustion system, with staged combustion systems tending to be the most complex. There is a perception that Gas Turbines operating with lean pre-mixing combustion systems (DLE/DLN) suffer combustion stability issues with changes in:

- Ambient temperature
- Fuel Quality
- Operating Loads

affecting exhaust emissions to atmosphere as well as reliability of the product.

Whilst this was true many years ago GT OEM's (as well as a number of non-OEM control suppliers) use a variety of methods to minimise the impact of change to ensure compliance with local environmental regulations and achieving high availability and reliability of their GT products. Tuning has now been replaced with direct control requiring less site based manual intervention .

It is not possible to describe all methods due to the different combustion systems employed, for example staging, mode switch between diffusion to full lean pre-mixing etc., but in most cases the control systems used have additional methodology included which permits some degree of self-compensation or adjustment to ensure a pre-defined map of operation is applied. This ensures the balance of exhaust emissions, NO_x and CO, typically, blow-out conditions and combustion vibration (or dynamics) are maintained to an acceptable level.

However, it is worth considering the system employed by Siemens in the light industrial gas turbines products. These products use pilot and main fuel control valves permitting lean pre-mixing across the full range of load. Rather than having pre-defined fixed pilot fuel schedules, this control methodology takes the existing measured operating parameters and automatically adjusts the pilot fuel schedule to ensure stable

operation is achieved whilst minimising the exhaust pollutants to atmosphere regardless of ambient temperature or load. This methodology also allows the control system to automatically and rapidly compensate for variability in the fuel gas composition without the need for external instrumentation such as calorimeters

Gas Turbine Fuels and Fuel Quality

Modern highly efficient gas turbines rely on high-quality alloys to allow increased firing temperatures to be achieved, whilst still maintaining acceptable product life. To ensure this is achieved, far more attention on the use of the fluids entering the gas turbine is necessary, including air, lubricating oil and fuels. Fuel quality is a major topic of its own, with some of the fundamental requirements associated with fuel quality discussed below, along with potential issues associated with poor fuel quality.

All Gas Turbine OEMs provide comprehensive specifications covering the fuel quality permitted for use in the gas turbine. These are used to ensure fuel quality is defined at the onset of a project and throughout the lifetime of the turbine and are prepared for good reason. To ensure acceptable turbine operation is achieved with little or no impact on major turbine component life, it is necessary to understand fuel composition and the supply conditions in more detail. Identification of contamination has become particularly necessary as this can have a detrimental impact on exotic materials used in turbine blading.

The choice of gaseous fuels as a primary fuel for use in gas turbines is dictated by their widespread availability and low price. Compositions of gaseous fuels can vary quite widely, from those taken directly from oil or gas wells which can contain high amounts of heavier hydrocarbons, to those containing non-combustible species (such as nitrogen, carbon dioxide, argon ...). In some cases quantities of hydrogen sulfide may be present, which, left untreated, can produce sulfur oxides in the exhaust, and, more significantly, can combine with halides to form compounds which readily attack the exotic alloys used in turbine blading, resulting in premature component failure.

Gaseous fuels can contain a wide variety of contaminants such as:

- Solids
- Water
- Higher hydrocarbons
- Hydrogen sulfide
- Carbon dioxide
- Carbon monoxide
- Hydrogen

The importance of providing a comprehensive fuel composition in order to determine the suitability of such fuels should not be under-estimated. Concerns and issues can be identified at this early stage to allow preventative measures, such as fuel treatment, to be taken.

Higher hydrocarbons influence the hydrocarbon dew point, and a high supply temperature is thus required. If the temperature is not maintained then liquid dropout (condensate) will result and can cause problems in the fuel system, or, more seriously,

impinge on combustor surfaces leading to localized burning and component failure, such as indicated in the left hand picture in Figure 15 below (occurred very rapidly and resulted in engine shutdown).



Figure 15: DLE Pre-chamber damage as the result of heavy hydrocarbon carry over and oxidation

Hydrogen sulfide combustion results in sulfur oxides in the exhaust (hence potential for acid rain). Of greater concern is the presence of alkali metal halides, such as sodium chloride or potassium chloride, and water vapour. These result in the formation of alkali sulfates, giving rise to aggressive corrosive attack of the nickel alloys used in modern turbine blades (the right hand picture in Figure 15 above). This example is after many operating hours.

Gaseous Fuel Assessment Criteria

A comprehensive assessment of gaseous fuels is necessary with a number of factors used to determine the suitability. Some of these discussed below can be inter-related, such as the presence of water and solid contaminants.

Wobbe Index; Temperature Corrected Wobbe Index

Pipeline quality gas fuels contain mostly methane, with small quantities of ethane, and typically fall into the range 37 – 49 MJ/m³ Wobbe Index.

Wobbe Index (WI) is one of the parameters used to assess fuel and allows a direct comparison of different fuels to be made based on heat content. Wobbe Index (or Wobbe number) is the Net (lower) calorific value of the fuel divided by the square root of the fuels specific gravity.

Wobbe Index

$$WI^0 = CVv^0 / \sqrt{SG^0}$$

Where CVv^0 = net calorific value (MJ/m³) at standard conditions (288K, 1.013bara)

SG^0 = specific gravity at standard conditions

$$= \rho_{fuel} / \rho_{air}$$

where ρ_{fuel} and ρ_{air} are at standard conditions (288K, 1.013bara)

Fuels can be, and are often, provided at different supply conditions. Therefore the use of Temperature Corrected Wobbe Index (TCWI) becomes an important aspect when reviewing fuels. Gas fuels containing water and or higher hydrocarbon species will result in higher dew point requirements, hence the need to provide a set amount of superheat margin, ensuring the gas remains in a vapour at all times.

$$WI^T = WI^0 \sqrt{288 / T_{fuel}}$$

Where:

T_{fuel} is temperature of fuel at turbine skid edge (K)

WI^T = Temperature Corrected Wobbe Index

WI^0 = Wobbe Index at standard conditions, 288K

Fuels with visually different compositions may have the same Wobbe Index and therefore same heat content. However, other factors such as dew point need to be evaluated.

GT OEM's have limits on ranges of fuel CV or WI before it becomes necessary to introduce changes in combustion hardware. This may be as simple as geometry changes within the same burner, or require more extensive modifications and involve fuel system changes. The objective is to achieve a similar fuel supply pressure and pressure drop across the burner to ensure stable combustion is maintained.

Dew Point and supply temperature

Gaseous fuels comprise a variety of hydrocarbon species, each of which has a unique "dew" point temperature, i.e. the temperature at which the gas condenses producing liquids, and those fuels which also contain water will have in addition a water dew point (Figure 16) {7}. Thus it is possible to determine the dew point for a known gas at a given pressure. It is normal to apply a margin of superheat over the calculated dew point to prevent condensate or liquid drop out. Some OEMs apply a minimum of 20°C, but others may apply higher levels, commonly 25-30°C. Fuels which contain higher hydrocarbon species may require a higher margin of superheat to be applied.

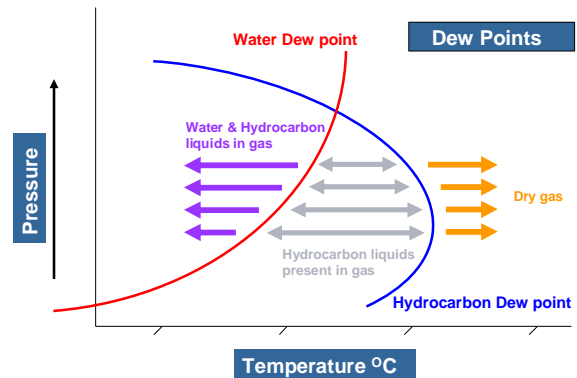

Figure 16: Water and Hydrocarbon Dewpoint

Water

Pipeline quality gas fuels are usually clean and dry, but there are occasions when fuels contain water, the presence of which can be problematic:

- Free water in the presence of hydrogen sulfide or carbon dioxide can form acids which can be highly corrosive to the fuel system and associated pipework
- Water may contain undesirable water-soluble contaminants
- Impacts dew point (water dew point), hence supply temperature will be higher than for the equivalent dry gas

Removal of water using best industrial practices should be considered.

Higher Hydrocarbon Species

The presence of higher hydrocarbon species impacts the dew point, and hence the supply temperature. Higher hydrocarbon liquids, or condensate, when passed into the combustor, can combust in an uncontrolled manner:

- condensate is un-metered; results in uncontrolled combustion
- detrimental effect on operation, safety
- can result in both combustion hardware damage or failure, as well as damage to downstream hot gas path turbine components
- Burner gas gallery and passage blockage due to carbonization

The temperature adjustment of fuels also has some additional considerations:

- Allows some richer fuels to be supplied at a temperature beyond that required for dew point control
- Trace heating and lagging of the gas supply pipework and fuel system would be required

Contaminants in gaseous fuels

Water is one contaminant already discussed, but there are other contaminants that are often met and need to be considered

Carbon Dioxide (CO₂)

CO₂ can react in the presence of moisture producing a weak acid, but mostly it acts as a diluent reducing the heat content available in the fuel.

Hydrogen sulfide (H₂S)

Hydrogen sulfide is highly toxic and can pose unique challenges to operators as well as in the operation of gas turbines. Besides specific health and safety requirements, H₂S (also sulfur in liquid fuels) can combust producing SO_x (SO₂/SO₃) emissions to atmosphere, which react in the presence of moisture resulting in weak acid production (acid rain). Where SO_x legislation exists, treatment of the fuel at source to remove or lower H₂S (or sulfur in liquid fuels) is necessary. In the presence of sodium, potassium or vanadium, such as found off-shore or in coastal environments, further assessment will be required as the reaction of these metals and their salts with sulfur results in the production of sodium and potassium sulfates or vanates which are highly corrosive to modern materials used in the hot gas path components, such as turbine nozzles and rotor blades.

Hydrogen and Carbon Monoxide

These readily combust, but require special understanding before acceptance as a GT fuel. Both exacerbate combustor flame speed, and can result in flashback, where the flame velocity exceeds the local combustor velocities. This makes these types of fuels less suited for lean pre-mix type combustion systems. However, conventional diffusion flame

combustion systems are more tolerant to such fuels, subject to full assessment and application of appropriate safety measures.

Gas Turbine Fuel Flexibility

Table 1 highlights the extensive range of fuels that can be encountered for GT applications. This demonstrates the need for wide fuel flexibility in normal operation. When coupled with the requirement to be “environmentally” compliant and meeting increasingly stringent exhaust emissions legislation, the need to combine fuel flexibility with low emissions combustion technology has focused the research and development minds of many of the GT OEMs.

Take, for example, the combustion technology employed by Siemens with its can-annular type combustor supported by purpose-built comprehensive rig facilities to enable fuel expansion developments. Operating combustion test facilities at true engine operating conditions of temperature and pressure within a single combustor allows for rapid evaluation of the discrete changes necessary to achieve satisfactory operation on a wider range of gas fuels, particularly ‘weak’ fuels {8}. Weak fuels contain increased levels of inert species, such as carbon dioxide and/or nitrogen, and so have a lower ‘energy content’ and therefore require an increased fuel volume to achieve the same energy content as regular pipeline quality fuels. To minimize operational impact it is also desirable to maintain combustion properties at similar levels to ‘standard’ fuels. Gas Turbine supply pressures, along with combustion pressure drop, are aspects which must be considered, as shown in figure 17.

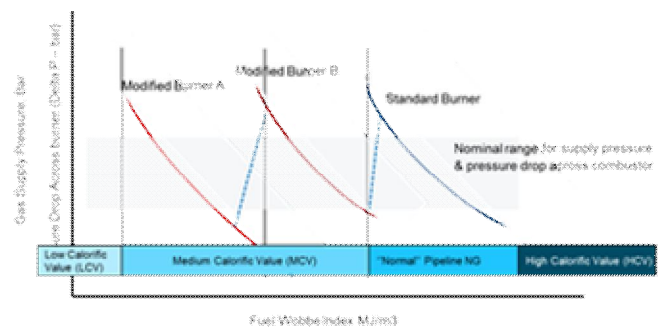

Figure 17: Impact of Fuel Quality on supply pressure and combustor pressure drop

Discrete changes to the combustion hardware as well as the fuel delivery system are made to ensure the increased volumes required are provided at conditions commensurate with standard pipeline gas fuels.

Gas fuel composition also has an impact on the NO_x emissions, even in a DLE combustion system. Weak gases tend to have slightly lower NO_x emissions than natural gas, as the inert gas content appears to quench the flame temperature, whereas ‘rich’ gases with higher levels of ethane, propane and butane than seen in natural gas cause an increase in NO_x emissions. Unlike ‘pure’ nitrogen content in the fuel gas, fuel-bound nitrogen, though (for example if the gas contains ammonia NH₃) converts to NO_x in the combustion process, increasing emission levels

‘Pipeline’ quality Natural Gas fuels

Gases extracted from underground sources – wellhead or associated gas – undergo processing resulting in a high quality product that can be used by industrial and domestic users alike. Comprising mostly methane, CH₄, natural gas can also contain small amounts of ethane, C₂H₆, and propane, C₃H₈. Inert species such as Carbon dioxide, CO₂, and Nitrogen, N₂, may be present in small quantities. The processing also ensures pipeline gas fuels are dry and free from any moisture. Gas fuels can also originate from oil wells, and in this case are termed “wellhead” or “associated” gas; gas wells and condensate wells are sources that may be entirely free of crude oil. In all of these cases, the gas requires processing to remove higher hydrocarbon species and gaseous contamination, such as hydrogen sulfide and water, to ensure gas is clean and dry before it is allowed to enter natural gas pipelines. Strict control on gas specification is made to ensure the gas fuel entering the pipeline from whatever source does not vary significantly. “Waste” hydrocarbon products from gas processing are themselves valuable. These are often termed natural gas liquids (NGLs) and include ethane, propane and butane for example. Separating these and selling them in the open market as, for example, LPG, is a good way of ensuring all gases recovered from the wells are utilized.

Other Types of Fuels encountered for use in Industrial Gas Turbines

Pipeline quality gas fuel has been shown to be the primary source of fuels for gas turbine applications mainly due to its widespread availability and low cost. However, there are many other fuels which are used or considered, especially where pipeline gas is either not available or of insufficient quantity.

Premium liquid fuels

Diesel fuel and Kerosene processed to internationally recognized quality standards are used either on their own or in conjunction with gas fuels (dual fuel operation). Distillate fuels (No2 Diesel and Kerosene, for example) are processed from crude oil and can be made to a wide range of specifications. Other liquid fuels such as natural gas liquids or higher hydrocarbon liquids, such LPG (a mixture of propane and butane), are also produced and have been used as a gas turbine fuel, although special consideration is needed in such cases. Figure 18 highlights the range of liquid fuels compared to natural gas.

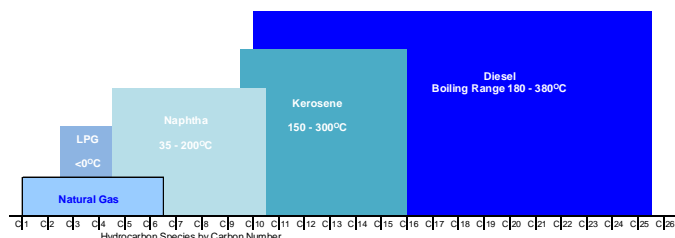

Figure 18: Liquid fuels typical encountered for gas turbine use, compared to natural gas

The suitability of commercially available diesel fuels must be assessed and compared to the OEM’s own specification. Several international specifications exist, all with small differences that can make a huge difference in gas turbine operability. Typical Specifications include EN590 and ASTM D975 along with Low and Ultra Low Sulfur diesels (LSD and ULSD) {9}.

Alternative liquid fuels to fossil diesel are becoming more widespread such as paraffinic biodiesel and liquids derived from natural gas, the latter via conversion techniques such as Fischer Tropsch and commonly referred to as “Gas to Liquids” or GTL fuels (similar fuels include BTL – biomass to liquids and CTL – coal to liquids). Although production quantities are small today these will grow in years to come and either will be blended with fossil diesel or used as a stand-alone fuel. Specifications for such fuels are in development, such as TS 15940:2012, covering Paraffinic biodiesel fuel, {10}.

LNG (Liquified Natural Gas)

LNG is available from a wide variety of sources and can vary significantly in properties due mostly to the content of Ethane, C₂, in the composition (in place of methane). LNG has a tendency to be higher in Wobbe Number than standard pipeline quality natural gas, so may require Nitrogen dilution to ensure compatibility with general pipeline quality fuel specifications.

Wellhead Gases as a Gas Turbine Fuel

Alternative gaseous fuel solutions for gas turbines are used where export of the gas fuel from source makes little economic sense. Assessment and use of wellhead, or associated, gas fuels can allow marginal wells and locations to be developed. Each fuel is assessed on its merits with some recommendations made regarding minimal cleanliness, water content, dew point control, all of which have been covered in detail.

Unconventional Gaseous Fuels

Coal Bed Methane / Shale Gas
Unconventional gas implies gas fuels extracted from coal beds (coal bed methane or coal seam gas) or from shale rock using the technique called fracking. The merit of this process is not discussed, but rather the fuel extracted and treated. The method may be unconventional, but once passed through a cleaning process the gas is very much conventional and can be treated in the same way as pipeline quality gas or LNG.

Biogas fuels

These are weak methane-based gas fuels (can be referred to as medium or low Btu fuels) which contain high levels of carbon dioxide, CO₂ and/or Nitrogen, N₂. They can be naturally occurring or derived for example from the decomposition of waste material (Land Fill Gas - LFG) or from anaerobic digestion (AD) process or Waste Water Treatment Process (WWTP), and can be considered as a useful fuel for gas turbines {11}. LFG, AD, or WWTP are sometimes recognized as renewable fuels and can gain ‘green’ accreditation and additional economic benefits. There are many examples of gas turbines operating on these weak fuels using conventional combustion, but in recent times extended fuels capability using low emission combustion configurations have been developed.

With such fuels it is a requirement of the fuel system to provide sufficient quantity of fuel to sustain stable combustion and be responsive to variations in such fuel sources.

There is an appreciable increase in flow through the turbine when compared to standard pipeline quality gas fuels, resulting in additional output power. Power is a function of mass flow through the turbine (sum of air flow through the compressor and from the fuel source) and therefore for a medium CV fuel, the fuel mass flow is increased to achieve the required energy content compared to natural gas which can result in an increase in power output.

Figure 19 shows a 13MW class gas turbine operating on a weak gas with a TCWI of approximately 21MJ/m³, nearly half the CV of pipeline quality gas fuels {8}.



Figure 19: Gas turbine operating on weak gaseous fuel (photo courtesy of Siemens)

Refinery; Process Off-gas; Hydrogen Syngas

Process off-gas, such as a refinery tail gas, can be used as a suitable gas turbine fuel. These tend to contain high levels of Hydrogen and sometimes Carbon Monoxide; therefore special consideration has to be made for these types of fuels.

Syngas also falls into this category, but these are mostly derived from the gasification or pyrolysis of coal, petcoke, various wood types, or municipal or agricultural waste products. These are low in heating value compared to biogas, for example, but comprise Hydrogen and Carbon Monoxide as well as quantities of inert species, CO₂ and N₂. All of these need special consideration due to the impact each has on combustor flame speeds and the propensity for “flashback” and the resultant damage to combustion hardware.

Hydrogen-rich fuels have been used with some success, but require the use of conventional combustion as such fuels tend to “flash back” in lean pre-mix combustors, with consequential hardware damage. Wet injection can be applied to reduce atmospheric pollution. A derivative of this capability is gases produced from coke batteries in the steel making process. Coke Oven Gas, COG, is high hydrogen, but also contains methane and to a lesser extent CO. Conventional, diffusion combustion system is applied but additional gas cleaning is essential to

prevent a shortening of the hardware life due to the effects of contamination found in such gas fuels.

Natural Gas Liquids and LPG fuels

Less used, but still viable, gas turbine fuels include those containing higher hydrocarbon species. These require specific assessment and consideration within both the fuel system and combustor injector.

LPG can be used either in vaporized or liquid form. When vaporized and maintained in gaseous form, the gas should be supplied at elevated temperatures due to the use of the higher hydrocarbons usually associated with LPG, butane and propane. Special injectors will be required to ensure the metered fuel is correctly controlled.

When supplied in liquid form special consideration must be made to the fuel system. LPG has a very low viscosity and special pumps are required to overcome the problem of low lubricity associated with LPG. Control of the fluid is critical to ensure other problems are avoided such as:

- Waxing (fuel temperature too low)
- Exceeding flash point (temperature too high)
- Corrosion (particularly where copper is present)
- Vapor lock due to premature vaporization of liquid

Storage of such fuels needs particular attention. Having a lower viscosity in liquid form and being heavier than air when in gaseous form means special precautions have to be adopted.

Crude Oil as a GT fuel

Viscosity is one of the key parameters used when evaluating liquid fuels for use in industrial gas turbines and generally should be <10cSt @ 50°C (most regular diesel fuels <7.5cSt @ 40°C). However, there are some gas turbine models that are able to operate on liquid fuels with much higher viscosities, and can, by using fuel heating or blending, operate on fuels with viscosities up to around 1000cSt @ 50°C

There are cases where neither diesel nor gaseous fuels are available or economic to use, and the only suitable “fuel” is crude oil. This creates challenges that have to be handled through fuel pre-treatment and fuel injection system functionality {12}. Firstly, heating the fuel reduces the viscosity, but noting the limitations:

- First is 100°C, at which water boils off (all liquid fuels contain a small amount of water) causing cavitation in fuel pumps
- Increasing fuel oil supply pressure allows the heating to be extended beyond 100°C, but is limited by the temperature limits within the fuel delivery system
- Further heating can result in fuel cracking and coking in the fuel system and burners depending on the constituents within the crude oil

Crude oils need to be treated in order to meet industrial gas turbine limits on metallic and other contaminants in the fuel. Crude oil often contains high amounts of alkali metals (Na, K) and heavy metals (V, Ni, etc.) which if introduced into the combustion system can result in accelerated deposit formation and high temperature corrosion in gas turbine hot gas path components. Major corrosive constituents include Vanadium pentoxide (V₂O₅), sodium sulfate (Na₂SO₄) and aggressive low

melting forms in the $\text{Na}_2\text{SO}_4 - \text{V}_2\text{O}_5$ and $\text{Na}_2\text{O} - \text{V}_2\text{O}_5$ systems. Determination of the ash sticking temperature is usually a good feature to use, and should be $>900^\circ\text{C}$ if sticking to the blade is to be avoided.

Water and sediment can be removed, or reduced, by filtration and centrifuge separation. This is the same for any liquid fuel, and prevents the formation of corrosive elements and bacterial growth, a pre-cursor to fuel degradation. Removal of the water also reduces the levels of water-soluble contaminants such as the alkali metals sodium and potassium. Vanadium and other heavy metals are oil-soluble though, and can only be treated through chemical dosing so that combustion creates high melting temperature compounds. A magnesium-based additive is commonly used to treat fuels with heavy metal contamination.

Crude oils can also contain more volatile components with a low flash point, therefore the need to ensure the use of explosion proof equipment is often required.

Impact of Sulfur and Metallic Contaminants

Sulfur has various effects on turbine operation. It can be seen as hydrogen sulfide, H_2S , in gaseous fuel or as elemental Sulfur in liquid fuel. Components used in the hot gas path section of GTs can be impacted by the combined presence of Sulfur and other metallic contaminants such as Sodium and Potassium. Formation of sulfates can be highly corrosive to modern high temperature alloys used in Turbine nozzles and rotor blades.

Organic contaminants (tars and asphaltenes) and their impact

Tars tend to be present in small quantities in process gas fuels, such as those from the conversion of coal to coke, resulting in production of Coke Oven Gas, COG. Asphaltenes are small solid particles found in some distillate fuels. These can combine to form a more homogenous mass affecting the filtration system or collect at the bottom of storage tanks forming a sludge like substance.

Water in fuel

Clean dry fuel is essential in achieving best operation of an industrial gas turbine and the presence of contaminants can result in poor turbine operation and increased maintenance. Water in gaseous fuel can be tolerated, subject to correct control over dew point, but the water contained in distillate fuels is most concerning. It can be seen as dissolved, emulsified or free water.

- Dissolved water: chemically dissolved or absorbed into the fuel (e.g. sugar dissolved in hot drinks);
- Emulsified water: tiny droplets of water are suspended in the fuel, making it milky in appearance;
- Free water: falls out of suspension and gathered at the bottom of a storage tank.

It is these latter two types, emulsified and free water, which are of most concern, resulting not only in fuel system and engine damage, but also the promotion of bacterial growth.

Wet gas fuels need to be assessed to determine both hydrocarbon and water dew point. Minimum supply temperatures will then be based on the higher of the dew point,

subject to the temperature limit of the combustion and fuel system mechanical hardware.

Fuel Storage

Mostly related to liquid fuels, the storage and maintenance of such fuels can be the difference between acceptable turbine operation and one where extensive site maintenance may be required.

Storage of fuel comes under the general heading of fuel handling best practices.

- It is necessary to ensure fuel is sourced from good suppliers to approved specifications
- Routine monitoring and recording from sampling and analysis of fuels is critical to achieving good turbine operation
- Applying best industry practice in receipt, unloading, storage and transfer of liquid fuels is essential to achieving and maintaining fuel to the highest standard and quality
- Using centrifuges, filters and coalescers at each storage tank will help maintain the fluid in the correct condition
- Ensure tank design meets best industrial standards, including, but not limited to, floating suction take-off to supply the gas turbine; bottom drain for sediment and water; and allowing for sufficient settling time after introducing new supply to tank
- ‘Turning’ over the liquid fuel, i.e. using it all on a regular basis, minimizes deterioration and will also help in the long term quality control of the fuel.

This is by no means a comprehensive coverage of the use of liquid fuels but attempts to provide the essential aspects that need to be considered.

CONCLUSIONS

The understanding of fuels used in modern high performance, high efficiency gas turbines is a critical step in achieving the goals of high availability and reliability, but at the same ensuring the environmental needs are fully met. The impact of the wide range of fuels used in gas turbine combustion systems, especially those of the low emissions variety, has been considered.

In conclusion, the supply of the right quality fuels can result in the above requirements being met, while the use of fuels outside the advised specifications can result in increased maintenance requirements.

NOMENCLATURE

DLE	Dry Low Emissions
DLN	Dry Low NO_x
AFR	Air Fuel Ratio
CO	Carbon Monoxide
CO_2	Carbon Dioxide
N_2	Nitrogen
NO_x	Oxides of Nitrogen
O_2	Oxygen
SO_x	Oxides of Sulphur

SO ₂	Sulphur dioxide
SO ₃	Sulphur trioxide
UHC	Unburnt Hydrocarbons
H ₂ S	Hydrogen Sulphide
ppmv	parts per million by volume
COG	Coke Oven Gas
LPG	Liquid Petroleum Gas
WI	Wobbe Index or Water Injection
PSI/SSI	Primary Steam Injection/Secondary Steam Injection
WFR	Water to Fuel Ratio
SFR	Steam to Fuel Ratio
TCWI	Temperature corrected Wobbe Index
K	Absolute temperature in Kelvin
LCV(LHV)	Lower Calorific (Heating) Value
HCV(HHV)	Higher Calorific (Heating) Value
Btu	British thermal unit

- 9 Eric M Goodyear
Transport Fuels Technology
ISBN 0 9520186 2 4
- 10 TS15940: 2012
Automotive fuels - Paraffinic diesel from synthesis or hydrotreatment - Requirements and test methods
- 11 M Welch and P Martin
The Use of Medium Calorific Value gases from Biomass and Municipal Solid Waste in Industrial Gas Turbine
CEPSI 2002, Fukuoka, Japan
- 12 P Johansson, A Larsson
Heavy Crude Oil as a fuel for the SGT-500 Gas Turbine
World Heavy Oil Congress 2012, Aberdeen

REFERENCES

- 1 R McMillan and D Baker, October 2000
NO_x control in gas turbines - a comparison of approaches
IMEchE Seminar S706 - Meeting Limits on Emissions
- 2 TI Mina et al
A low smoke dual fuel injector with water and steam injection for industrial gas turbines
Powergen Asia 1997
- 3 B Zeldovich et al
Oxidation of Nitrogen in Combustion
Academy of Sciences, USSR
Moscow-Lenigrad 1947
- 4 H Alkabile, R McMillan, R Noden, C Morris
Dual fuel dry low emissions (DLE) combustion system for the ABB Alstom Power 13.4 MW Cyclone gas turbine
ASME
- 5 B Igoe and M McGurry
Design, Development and Operational Experience of ALSTOM's 13.4MW Cyclone Gas Turbine
ASME TurboExpo 2002
- 6 K Syed, E Buchanan
The nature of NO_x formation within an industrial gas turbine dry low emission combustor
ASME Paper Number GT2003-38211
- 7 TD Newbound and KS Al-Showiman
Tuning your Fuel Gas Delivery System
ASME Turbo Expo 2004, Vienna
ASME GT2004-53298
- 8 A Stocker and B Igoe
Extended Fuels Capability of Siemens' SGT-400 DLE Combustion System
IDGTE symposium 2013, Milton Keynes

ACKNOWLEDGEMENTS

There are many colleagues across Siemens Industrial Turbomachinery Ltd, whose contribution is recognized otherwise this paper would have not been possible. The authors specifically recognize the individual contributions from colleagues in the Combustion Group, Peter Martin, Victoria Sanderson, Ghenna Bulat and Eoghan Buchanan. Finally, the authors would like to thank Siemens Energy for permission to publish this paper.